

Resilient Flooring

FOR RESIDENTIAL AND COMMERCIAL APPLICATIONS



Durable

- Withstands diverse weight loads and temperatures
- Resists impacts and punctures
- Monolithic formulation eliminates wear layers, potentially lowering annual maintenance expenses



Sustainable

- Crafted from more than 90% recycled materials
- Millions of pounds of vinyl waste diverted from landfills each year
- Earn credits with the U.S. Green Building Council



Comfortable

- Designed to boost footing confidence in slip-prone areas
- Certified high-traction flooring by the National Floor Safety Institute
- 1/4-inch thickness reduces leg fatigue and absorbs sound



Sanitary

- Resistant to mildew and bacterial growth, it's impervious to water absorption
- Remains non-corrosive when exposed to chemicals, animal fats or grease
- Withstands routine cleaning without the need for waxing or stripping.

American Made. Made To Last.

For more than 30 years, Protect-All® has been producing our vinyl flooring right here in America. From concept to completion, we remain committed to providing you with high-quality, durable commercial flooring solutions designed to stand the test of time and backed by a 10-year warranty.

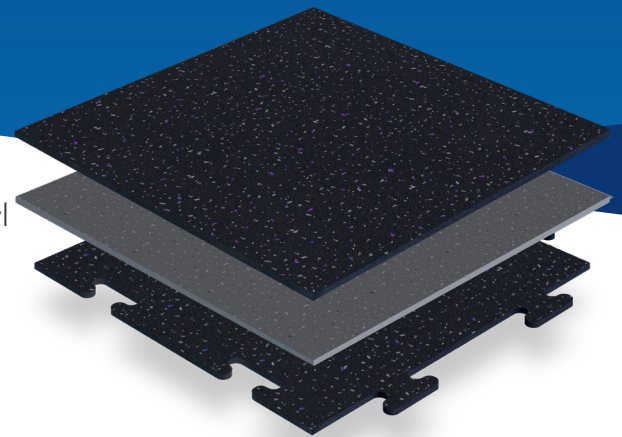

Technical Data

	Test Method	Units	0.25 in.
Weight	ASTM D-751	oz./sf	25.16
Dynamic Coefficient of Friction	ANSI A326.3		0.56
Coefficient of Friction*	ASTM D-695	Dry	0.88
Fire Test NFPA Type 1 Rated			
Critical Radiant Flux	ASTM D-648	w/cm ²	1.05
Burn Distance	ASTM D-648	cm	12
Breaking Strength	ASTM D-2047	lbs.	405 x 723
Compressive Strength	ASTM D-751	psi	641
Elongation	ASTM D-751	%	76.5 x 88.5
Shore A Hardness			80 - 85
Tear Strength	ASTM D-751	lbs.	76.5 x 84
Bacteria and Mildew Resistance	ASTM G-21		Pass
Dimensional Stability	ASTM F2199	%	0.1
Resistance to Impact	ASTM F1265		Pass

*For matte flooring only

Sizes

Protect-All flooring is available in five sizes and in thicknesses of 1/4" and 1/8". Protect-All Designer Series* is only available in 1/4" thickness.

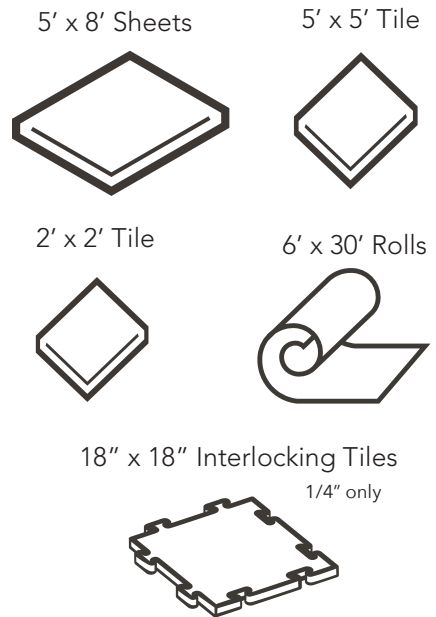

Installation Systems

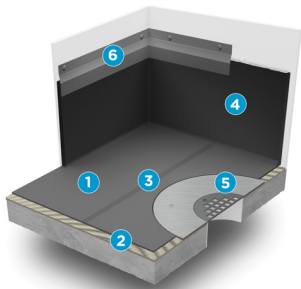

Heavy Duty Commercial

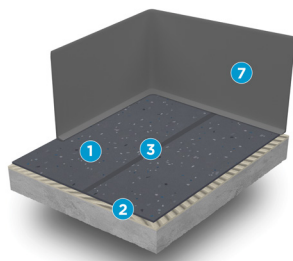

Commercial

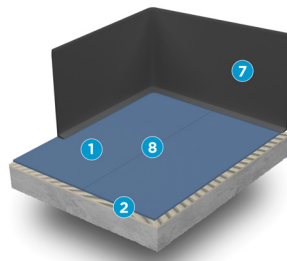

Commercial Non-Welded

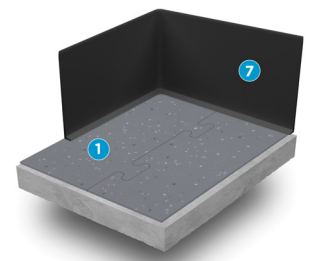

Loose Lay

- 1 Protect-All Flooring
- 3 Protect-All Raid-Weld
- 5 Drain Ring
- 7 Standard Cove Base
- 2 Two-Part Adhesive
- 4 Protect-All Cove Base
- 6 Z-Bar
- 8 Seam Sealer

 **Protect-All®**
Flooring
Durability Done Different

For more information give us a call or visit our website today.

800.544.9538
protect-allflooring.com

Manufactured by Oscoda Plastics® 5585 N. Huron Ave. | Oscoda, MI 48750



Oscoda Plastics is a brand owned by Holcim Solutions and Products US, LLC. "Protect-All" and "Oscoda Plastics" are registered trademarks owned by Holcim Solutions and Products US, LLC. OP080001 - ORG: 1.14 REV: 1.11.24